

**Packing Procedure
Recommendation
For**

YMC RP silica

ODS-A, ODS-AQ, Octyl, Butyl, YMCbasic



Schöttmannshof 19
D-46539 Dinslaken
Tel. (49) 02064/427-0
Fax (49) 02064/427-222

Content

1 RECOMMENDED PACKING TECHNIQUE	3
1.1 Slurry Preparation	3
1.2 Packing Procedure	5
1.3 Equilibration	6
1.4 Quality Control.....	7

1 Recommended Packing Technique

YMC RP silica is mechanically rigid and can therefore be packed efficiently as well in low pressure glass columns as in high pressure stainless steel and dynamic axial and radial compression columns.

1.1 Slurry Preparation

A thorough slurry preparation is the basis for good packing results. Please follow these steps to prepare the slurry:

1. Calculate the amount of media needed to get the required bed length from the specific packing density.
The packing density of YMC RP silica is approximately 0.65 kg/l.
2. Calculate the amount of organic solvent needed: For making up the slurry use at least 2 litres of solvent per kg of packing material.
We recommend **isopropanol (HPLC-grade)** for YMC RP silica.
3. Pour the calculated amounts of packing material and solvent into a vessel.

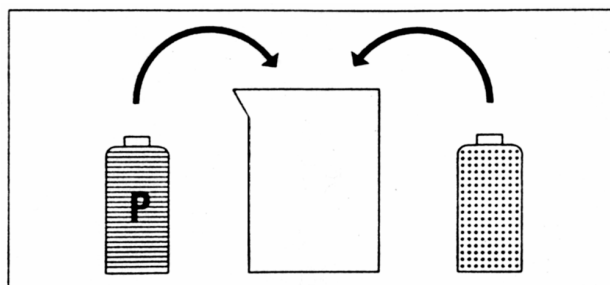

4. Stir thoroughly to achieve a homogeneous slurry suspension.

Note: Avoid rigid mechanical stirring. It may abrade the particles, which causes fines.

5. If any fine particles can be observed, remove them carefully from the surface after repeated sedimentation.
6. Degas for 10 minutes with an ultrasonic bath or by helium sparkling.

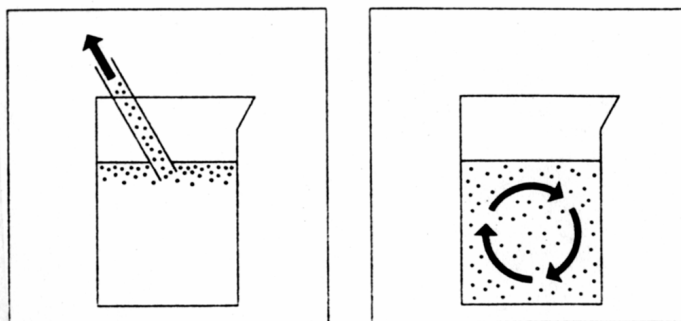

Example:

Desired column bed:	ID 100 mm x length 300 mm
Required bed volume:	2360 ml
Stationary phase:	YMC AA12S16
Packing density:	0.65 g/ml
Weight of stationary phase:	≈ 1500 g
Slurry solvent:	Isopropanol
Solvent volume:	≈ 3000 ml

1.2 Packing Procedure

To achieve the best possible result for your packing, work as quickly and reproducibly as possible. During packing avoid sedimentation, which will cause a loss in efficiency. Use an appropriate packing device or a slurry container.

Adhere to the following steps for column packing:

1. Clean the empty column and the frits (and if applied the packing device) thoroughly.
2. Introduce a few ml of solvent into the column, so that the lower frit is moistened and free from air bubbles.
3. Stir the slurry gently until it has a homogeneous consistency before filling it into the column.
4. Pour the slurry quickly into the column without introducing air bubbles. Take care for an even distribution of slurry during filling.
5. Compress the column bed as quickly as possible. Therefore refer to the column operating manual.

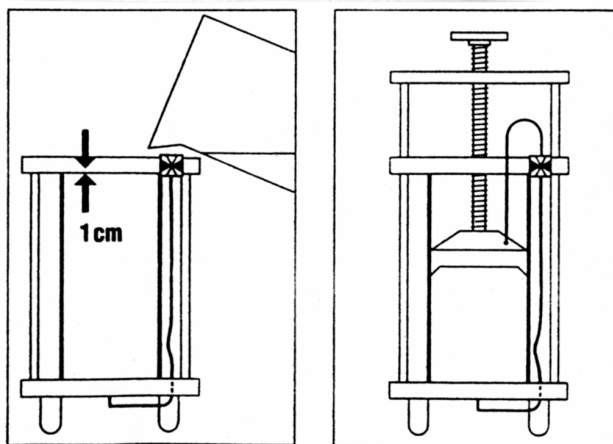

6. The flow rate should be adjusted slightly lower than the pressure limit of the column. Please refer to the column operating manual.
7. The flow rate during packing should always be considerably higher (>20 %) than the flow rate needed for later use.
8. Pumping must continue at least until a constant pressure is reached.

The whole packing procedure shall take maximum 4 to 5 minutes.

1.3 Equilibration

For the equilibration of the column we recommend an “equilibration run” of 10 to 20 times the bed volume. As mobile phase you should use the identical mobile phase as for your separation run.

1.4 Quality Control

We recommend determining plate count and peak symmetry with a suitable (non-adsorbent) test substance after packing the column.

By repeating this test frequently, the quality and durability of the packing can be monitored efficiently.

We recommend toluene as test substance for YMC bonded RP silica.

1. Plate count: $N = 5,54 \cdot (t_{Ri}/W_{1/2})^2$

2. Symmetry factor: $S = B/A$

